

Construction

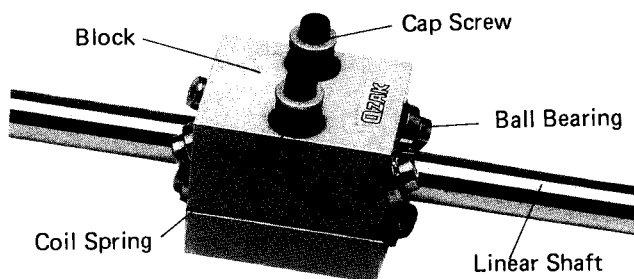

The SFS series features an aluminium block which is separated into two parts, an upper and a lower part. A group of three ball bearings is installed respectively on both ends of this block at an angle equivalent to the lead angle. This friction-drive feed screw allows a fitting adjustment between the block and linear shaft by either loosening or tightening both the coil spring and cap screw corresponding to the acting thrust load.

Precision

Table 158 : Adjustment Specs. Unit : mm

Backlash	0.025 or less
Lead Error	±0.038 or less per revolution

Because of the unit's friction-drive mechanism, the repeat positioning accuracy may change due to a possible slip caused by the variations of the acting thrust load magnitude, the inertia force, the lead size etc. For high-precision positioning accuracy, use the closed-loop control system.

Lubrication

Due to the use of a grease supplied bearing, this series does not require additional oil lubrication, however, rust-prevention oil must be periodically applied on the linear shaft.

Selection

Based on the following conditions, choose the best size unit from the SLS series.

1 Thrust Examination

- 1) Acting thrust load (F_W) determination
 (For horizontal movement) $F = \mu W$ (7)
 (For vertical movement) $F_W = \mu W + W$ (8)
- 2) Maximum thrust load (F_{max}) determination
 $F_{max} = F_W + F_\alpha$ (9)
 $F_\alpha = W\Delta V/gt$ (10)
- 3) Choose a proper size corresponding to the above F_{max} value from the F_α rated thrust load list on the following page.

Minimum size (determined) (a)

where

- F_W : Acting thrust load (kgf)
- W : Total acting radial load (kgf)
- μ : Guide's friction factor
- V : Speed (m/sec)
- ΔV : Acceleration-deceleration speed difference (m/sec)
- g : Gravitational acceleration (9.8 m/sec²)
- t : Acceleration-deceleration time (sec)

2 Shaft Diameter Examination

- 1) Temporarily determine the lead value. Then use the following equations to obtain the rotational frequency and the speed.

$$n = 60 \times V/\ell \text{ (rpm)} \dots\dots\dots (11)$$

$$V = \ell \times n/60 \text{ (m/sec)} \dots\dots\dots (12)$$

- 2) Shaft diameter determination
 Use the Critical Speed ~ Installation Distance graph to determine the shaft diameter d.
 Minimum Shaft Diameter (determined) (b)

- 3) Determine the unit's best suited size based on both (a) and (b).

Driving Torque

1) Load torque (T_1) determination

$$T_1 = F_W \cdot \ell / 2\pi \times 0.9 \quad (\text{kgf}\cdot\text{m}) \dots \dots \dots (13)$$

2) Acceleration torque (T_2) determination

$$T_2 = n \times \Sigma GD^2 / (375 \times t) \quad (\text{kgf}\cdot\text{m}) \dots \dots \dots (14)$$

3) Total load torque (T) determination

$$T = (T_1 + T_2) \times f \quad (\text{kgf}\cdot\text{m}) \dots \dots \dots (15)$$

where

- ΣGD^2 : Driving shaft-related aggregate GD^2 ($\text{kgf}\cdot\text{m}^2$)
- f : Safety factor 1.2 ~ 1.5
- t : Acceleration-deceleration time (sec)

Rated Life

1) Rated life in terms of total number of revolutions

$$L_n = (C/F_{\max})^3 \times 10^6 \quad (\text{rev}) \quad (16)$$

2) Service life in hours

$$L_{hr} = L_n / (60 \times n) \quad (\text{hr}) \quad (17)$$

3) Service life in travel distance

$$L_{km} = L_n \times \ell / 10^6 \quad (\text{km}) \quad (18)$$

where

- C : Basic dynamic load rating (kgf)
- ℓ : Lead (mm)
- n : Rotation frequency (rpm)
- $F_{\max} = F_W + F_\alpha$ (kgf)

Critical Speed

$$(\text{Critical Speed}) N_c = \alpha \cdot 1.22 \times 10^7 \times \lambda^2 d / L^2 \quad (19)$$

where

α : Safety factor = 0.8

- λ : Mounting factor
- Supported ~ Supported $\lambda = \pi$
- Fixed ~ Supported $\lambda = 3.927$
- Fixed ~ Fixed $\lambda = 4.73$
- d : Shaft diameter (mm)
- L : Mounting distance (mm)

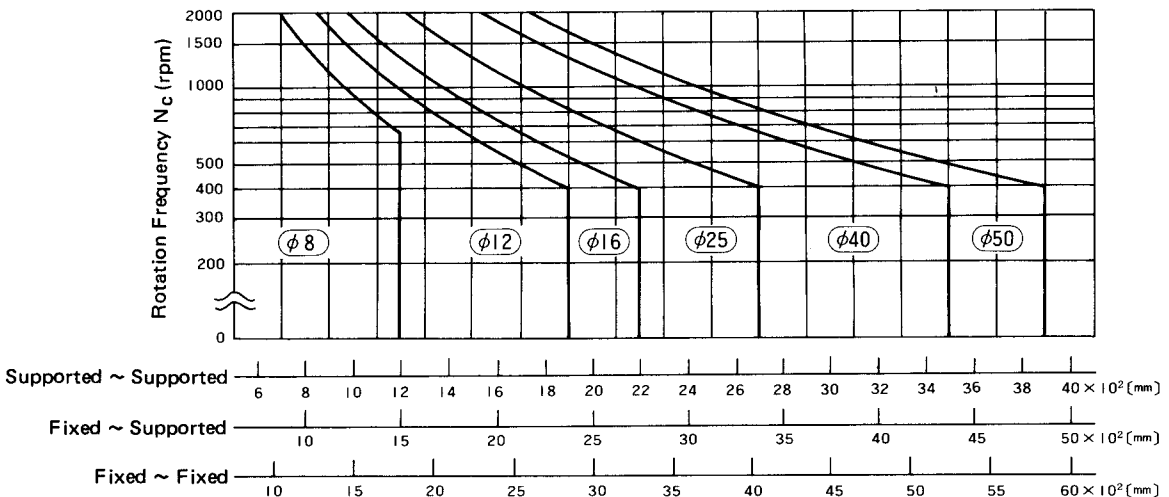

Fig. 42. Mounting Distance L (mm)

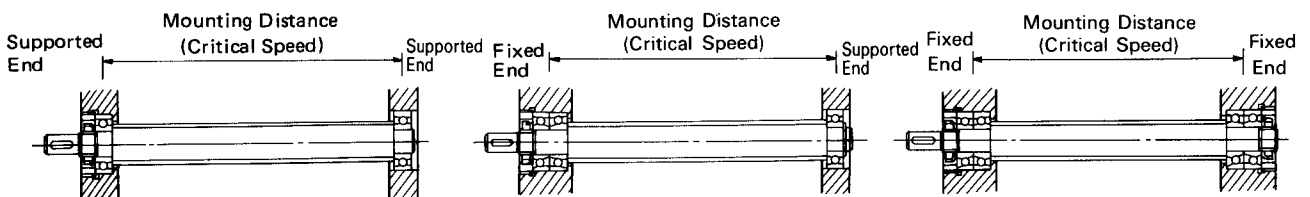
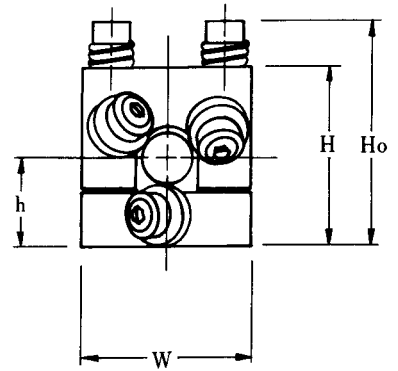
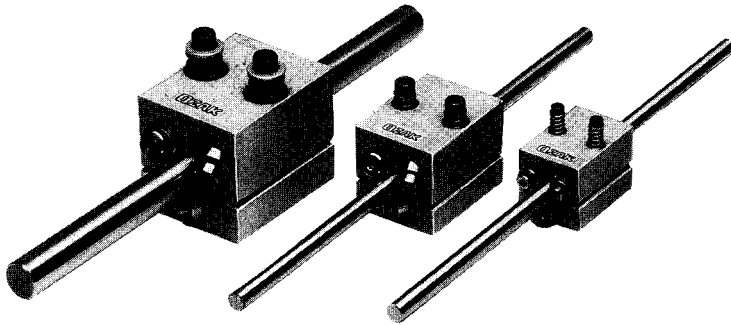
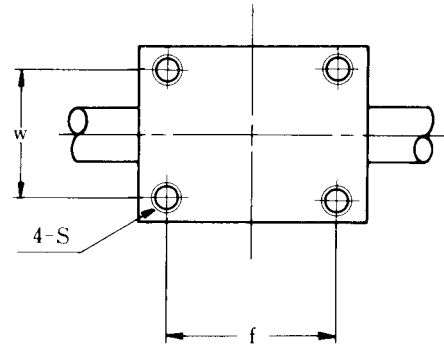
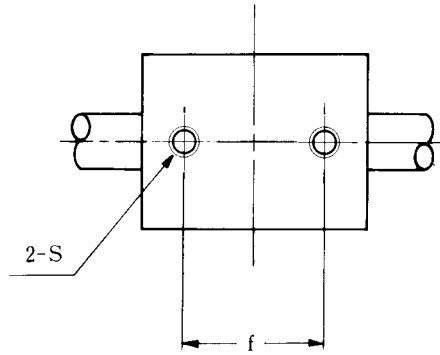
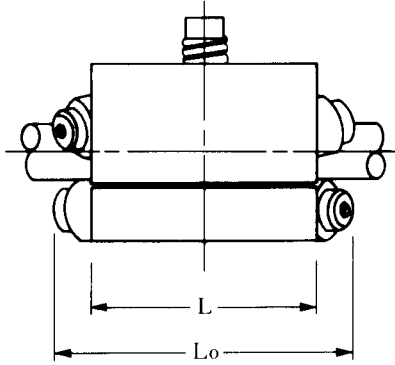

Fig. 43.

Table 159 : SFS Series Dimensions Table

Model No.	Shaft Dia. d (mm)	Lead ϕ (mm)	h	W	L	Major Lo
SFS-0825	8	2.5	14.5	28.4	41.1	57.2
SFS-0815	8	15	19.3	38.1	50.8	71.4
SFS-1215	12	15	19.3	38.1	50.8	71.4
SFS-1225	12	25	19.3	38.1	50.8	71.4
SFS-1615	16	15	25.6	50.8	63.5	85.8
SFS-1625	16	25	25.6	50.8	63.5	85.8
SFS-2525	25	25	38.1	76.2	63.5	90.4
SFS-4010	40	10	57.2	114.3	69.9	118.9
SFS-5050	50	50	57.2	114.3	69.9	118.9



SFS-08~16

SFS-25~50

Dimensions (mm)					Rated Thrust Load F_a (kgf)	Basic Dynamic Load C (kgf)	Weight (kgf)
H	H_0	w	f	S			
29	42.2	—	19	M3×0.5 depth 6	2.2	15	0.15
38.6	48.5	—	25.4	M5×0.8 depth 9	13.5	50	0.25
38.6	48.5	—	25.4	M5×0.8 depth 9	13.5	50	0.25
38.6	48.5	—	25.4	M5×0.8 depth 9	13.5	50	0.25
51.3	68.3	—	31.8	M6×1.0 depth 12	27.0	100	0.50
51.3	68.3	—	31.8	M6×1.0 depth 12	27.0	100	0.50
76.2	88.9	63.5	38	M6×1.0 depth 12	45.5	200	1.05
114.3	118.9	101.6	38	M6×1.0 depth 12	90.0	350	2.70
114.3	118.9	101.6	38	M6×1.0 depth 12	90.0	350	2.70

* H_0 : Case of no thrust load