



Corrosion Resistance Test The OZAK ML Series of rustproof type linear bearings features outer race surfaces with the most outstanding corrosion resistance; and, for finishing, a surface treatment process has been used assuring the highest degree of uniformity. As a result, the OZAK ML Series bearings have a clearly superior resistance to corrosion than the conventionally used stainless steel bearings made of steel grades SUS440C or QD51. The following salt spray fog test results testify to the much superior corrosion resistance performance capabilities of the ML Series.

This is why the ML Series is ideally suited for the work environments requiring a high corrosion resistance—a consideration that has played an increasingly more important role in recent years.

■ Test Methods

Test Method	Salt spray fog test to JIS H 8617 and Z 2371
Test solution composition	Sodium chloride 5.0±1%, pH 6.5—7.2
Grade of table salt (NaCl) used	Special grade to JIS K 8150
Quality of water used	Use of water purified in ion exchanger (resistivity 50×10^4 Ohm cm or more).
Specimen surface preparation	Cleaning with ethanol
Test time	96 hours
Spraying method	Continuous spraying for 24 hours
Assessment method	Rating scores to indicate the extent of red rust formation on the specimen surface

■ Test Results

Specimen	No.	Test Time (hr)								
		2 hr	5 hr	8 hr	16hr	24hr	36hr	48hr	72hr	96hr
Rustproof ML Series	1	10	9.8	9.8	9.8	9.8	9.5	9.5	9.5	9.5
	2	10	10	10	10	9.8	9.8	9.8	9.8	9.8
	3	10	9.8	9.8	9.8	9.8	9.8	9.5	9.5	9.5
Stainless Steel SUS 440C or QD51	1	9.0	8.0	7.0	6.0	6.0	6.0	6.0	5.0	5.0
	2	9.0	8.0	8.0	8.0	7.0	6.0	6.0	5.0	5.0
	3	8.0	7.0	7.0	7.0	7.0	7.0	7.0	5.0	5.0

*M Series: This series offers the most effective protection against rust: Outer races have OZAK, with the M-Series anti-rust surface treatment while the balls use stainless SUS440C.

*M2 Series: This is a more economic rustproof series: Outer races have OZAK, with the M-Series anti-rust surface treatment while the balls use stainless SUJ2. In general working conditions, there is only an extremely small probability of rust development on the oil- or grease-lubricated balls while rotating during operation.

The evidence of the salt spray fog tests has demonstrated that the OZAK M Series bearings have a much more favorable corrosion resistance than those using stainless steel (grades SUS440C. and QD51). The test results have already demonstrated the effectiveness of the rust protection that is the hallmark of this series. Yet the acid resistance of these bearings is often called into question when inquiries are made. We have conducted acid corrosion tests to determine the behavior of this series under acid exposure conditions. The results are reported below.

1. Resistance to Hydrochloric Acid

Resistance to hydrochloric acid systems is determined on the basis of the hydrogen chloride spray test results. These tests have shown that the OZAK M Series has a much higher corrosion resistance to hydrogen chloride than the stainless steel bearings. For comparative assessment, the hydrogen chloride spraying test results for the OZAK M Series and for stainless steel bearings are compared in the table below using rating scores.

2. Resistance to Nitric Acid

Test Method: Nitric Acid Fuming Test to JIS H8616 4,5,3 Test

Conditions: Introduce 150cc of first-grade reagent-type nitric acid into the bottom of a 20cm glass desiccator and close desiccator lid. Leave for 30 minutes to let the nitric acid gas (fumes) fill the interior of the desiccator. Then place the degreased (ethanol-cleaned) specimen on the center board in the desiccator and close lid. Leave in this condition and observe the changes of the specimen surface.

Test Results

Specimen No. Exposure Time	OZAK M Series					Stainless Steel (440C or QD51)				
	1	2	3	4	5	1	2	3	4	5
15 minutes	No rust formation					No rust formation				
30 minutes	No rust formation					No rust formation				
1 hour	No rust formation					No rust formation (Clouding discoloration of surface)				
1.5 hours	No rust formation					Some rust formation				
2 hours	No rust formation (Black discoloration of surface)					Rust formation on entire surface Rating score 2 3 2 3 3				

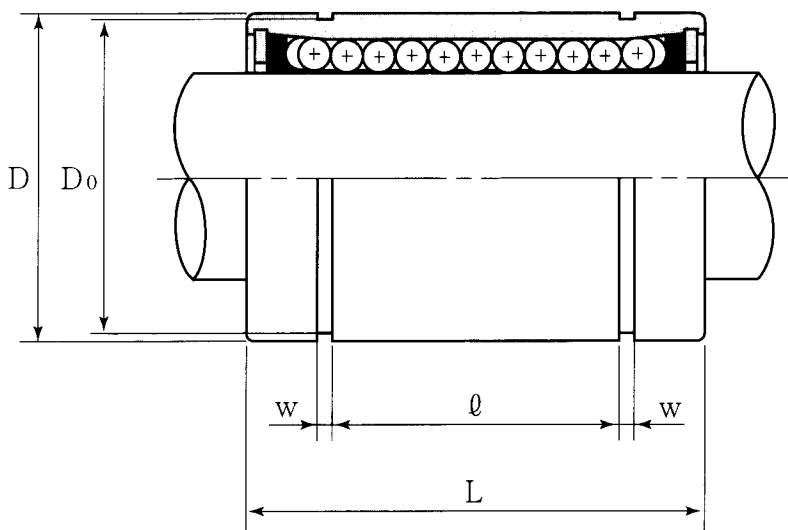
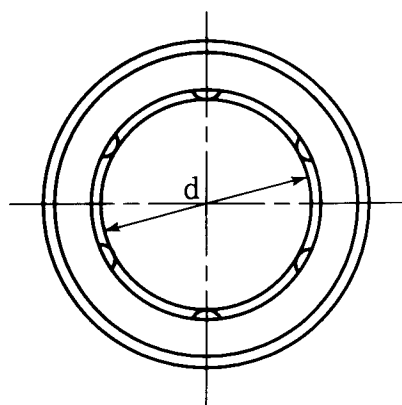

Table 7 : ML Series Dimensions Table

Shaft Dia (mm)	Model No.		Major Dimensions (mm)								Number of Ball Circuits	Weight (kgf)	Basic Load Ratings						
	Both Sides Sealed		d	D	L	l	w	D ₀	C	C ₀									
3	ML3	ML3-UU	3		7		10		—		—	—	4	0.0018	2	4			
4	ML4	ML4-UU	4	0 -0.008	8	0 -0.010	12	0 -0.12	—		—	—	4	0.0028	3	6			
5	ML5	ML5-UU	5		10		15			8		1.1	9.6	4	0.004	4.5	9		
6	ML6	ML6-UU	6	0 -0.009	12	0 -0.011	19	0 -0.2	±0.2	11		1.15	11.5	4	0.007	7	11		
8	ML8A	ML8A-UU	8		15					17		9		1.15	14.3	4	0.012	8	12
8	ML8B	ML8B-UU	8		15					24		15		1.15	14.3	4	0.014	11	16
10	ML10	ML10-UU	10	0 -0.013	19	0 -0.013	29	0 -0.2	±0.3	19		1.35	18.0	4	0.026	20	30		
12	ML12	ML12-UU	12		21					30		20		1.35	20.0	4	0.032	28	43
13	ML13	ML13-UU	13		23					32		20		1.35	22.0	4	0.040	30	52
16	ML16	ML16-UU	16		28					37		23		1.65	26.6	5	0.07	46	76
20	ML20	ML20-UU	20	0 -0.010	32	0 -0.016	42	0 -0.3	±0.3	27		1.65	30.3	5	0.09	52	103		
25	ML25	ML25-UU	25		40					59		37		1.9	38.0	6	0.21	104	193
30	ML30	ML30-UU	30	0 -0.012	45	0 -0.019	64	0 -0.3	±0.5	40		1.9	43.0	6	0.24	148	226		
35	ML35	ML35-UU	35		52					70		45		2.2	49.0	6	0.35	167	250
40	ML40	ML40-UU	40		60					80		56		2.2	57.0	6	0.77	280	400
50	ML50A	ML50A-UU	50	0 -0.012	76	0 -0.019	100	0 -0.3	±0.5	75		2.7	72	6	1.43	402	647		
50	ML50B	ML50B-UU	50		80					100		68		2.7	76.5	6	1.43	402	647

*M2 Series : Economical price series (Outer sleeve using M series, Steel Balls using SUJ-2)
Model No. (For ex) M2L16-UU